

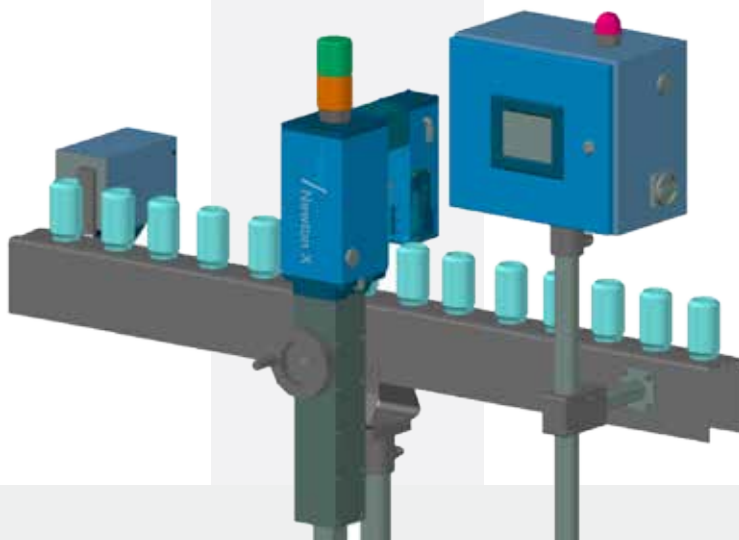

Newton X2P

Containers Fill Level Control



Average radiation

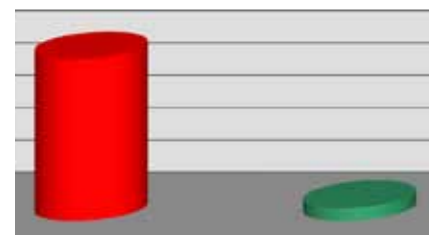

Traditional X-ray
fill level inspection units

miho Newton X2P

The miho **Newton X2P** is a X-ray fill level inspection unit that inspects cans, cartons lined with aluminium, foiled containers and bottles, and detects any underfilling and overfilling with the maximum level of reliability. It distinguishes itself by requiring less than a tenth of the average amount usually used for inspection by radiation for its measurement process. And thus the amount of radiation exposure is also reduced.

This reduction is due to X-ray technology developed for this purpose by miho *Inspektionssysteme*. Its core piece is a X-ray generator, which in contrast to traditional X-ray fill level inspection units only generates X-rays for a short moment during the measurement. The total radiation intensity is therefore only a fraction of what is the case with traditional X-ray fill level inspection units. The exact value depends upon the number of containers inspected. Another advantage of the X-ray generator being turned on only during the measurement is the considerable prolongation of the generator's life span.

miho **Newton X2P** is able in particular to achieve the same level of performance as the gamma ray fill level inspection units. In contrast to the gamma ray fill level inspection units, it is free of the legal regulations concerning transport, storage, use and disposal. Since radiation can only be emitted during the production process it is only necessary to issue an obligatory notice under German Law.

miho

Newton X2P

List of features

Technology and functions

- X-ray generator: Circular emitter.
Receiver: Circular detector.
- High level of measurement accuracy and reliability.
- The miho **Newton X2P** uses special algorithmic calculations irrespective of the type of container (can, carton, bottle), the dimensions of the container and the surrounding circumstances. For example, inaccurate calculations can be caused because the containers are not being transported smoothly and liquid surfaces that are uneven are therefore compensated for as much as possible.
- Evaluation unit with components of the standardized modular inspection unit system **miho Master**. High and diverse performance capability and easy maintenance.

Area of use

- Inspects the fill level in drink cans, carton packaging (even when aluminium coated), containers (even with foil) and glass bottles.

Operation

- High level of comfort through separation of the control cabinet and the inspection head.
- Comprehensive 5,7" colour display with touchscreen.
- Language selection.
- Bottle-type with corresponding fill level, changeable and can be saved.
- Extensive statistics.
- Adjustment to different nominal fill levels through easy to operate manual adjustment device.

Prepared for

- Cap detection for metal or/and plastic caps.
- Label detection module.
- Filler monitoring system **miho FM 2**.
- Operational data-processing.
- Remote maintenance.

Rejection

- Standard reject system **miho HSP**.
- Eccentric reject system **miho ESF 2**.
- Standing rejection (especially for plastic bottles):
Linear reject system **miho Leonardo M**.

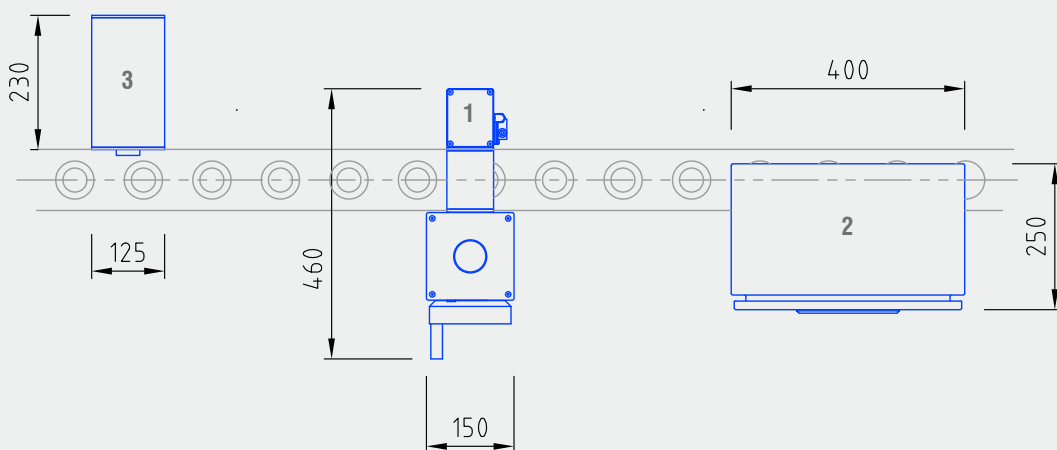

3: Reject System miho HSP

1: Inspection Head

2: Electronic Cabinet